

MODULAR CAB SHIELD OPTIONS

Cabshield	Overhang	Clearance	Window Size
Standard Height Quarter Cab Shield	14.9"	17"	21" x 9.6"
Standard Height Half Cab Shield	21.8"	18"	21" x 9.6"
Mid-Height Quarter Cab Shield	14.3"	20.6"- 23"	21" x 9.6"
Tall-Height Quarter Cab Shield	14.3"	24.6"- 27"	21" x 9.6"

Optional Bolt-on Cabshield Window Cover Available

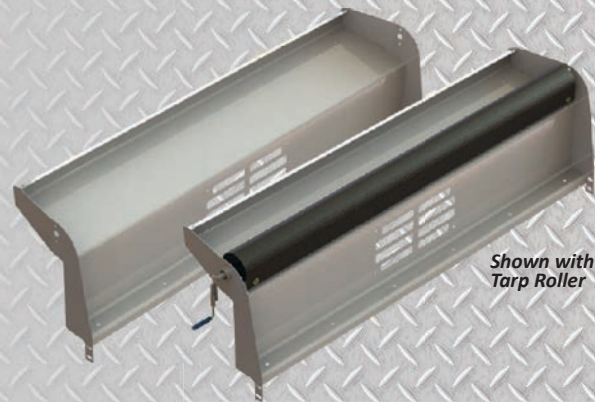

Shown with
Tarp Roller



Shown with
Tarp Roller



Shown with
Tarp Roller

OPTIONS & ACCESSORIES

- Pull-out ladder (powder coated or stainless steel)
- Asphalt apron
- Coal chute tailgate
- Toolboxes
- Cab shield lights
- 6" side board pockets
- Dejana mudflaps
- Bolt-on Cabshield Window Cover
- Tarp
- Pintle plate w/ D-rings
- 7-Pin trailer plug end
- Back up alarm
- Body up switch/ light
- Brake controller
- Reflective tape and more...



dyna/PRO

Dump Bodies Designed and Tested for
Superior Strength & Performance



BODY SPECIFICATIONS

(a) ASTM A572 GR50 Alloy Steel for Superior Strength and Corrosion Resistance

(b) Cross-memberless Understructure with Enclosed 10-ga. Trapezoidal Longsills

- Fully welded to unify body structure and provide superior strength
- Sleek design with no salt pockets

(c) Tubular Sidewall Construction

- 10 ga. inner & 12ga. outer wall interlaced with floor and underbody for superior strength & rigidity

(d) Scissor Lift & Sub-Frame

- Double acting heavy-duty hoist
- Redesigned subframe with bolt-on bracket accommodations
- Mounting brackets: sub-frame to chassis

(e) Rear Hinge

- .250" plates with .375" doublers on outside of clevis
- 1" OD zinc plated pin with cotter pin

(f) Slide Lock Upper Tailgate Latch

- 2-point latching system with ergonomic design to maximize leverage and improve serviceability
- Built-in tarp bar retention hooks

(g) Ergonomic Hand-held Controller

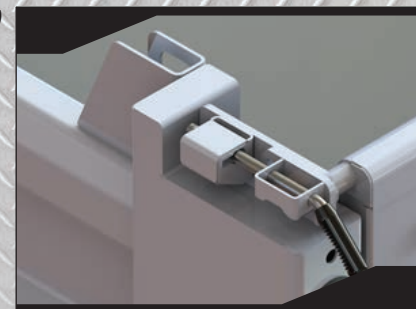
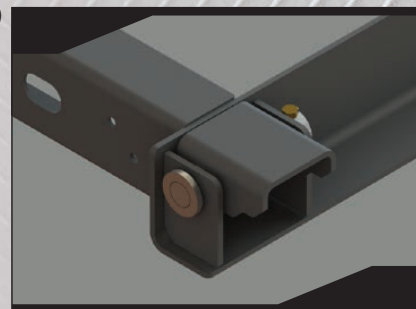
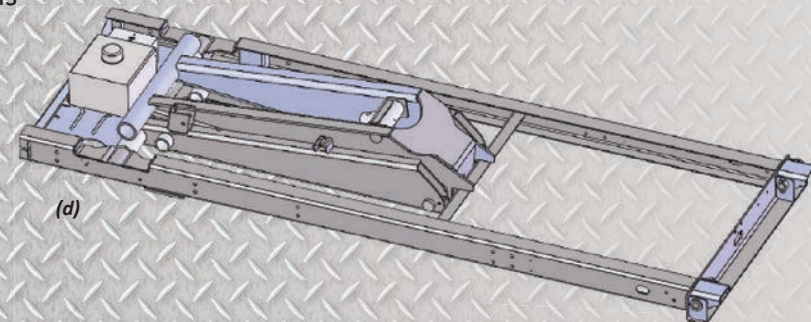
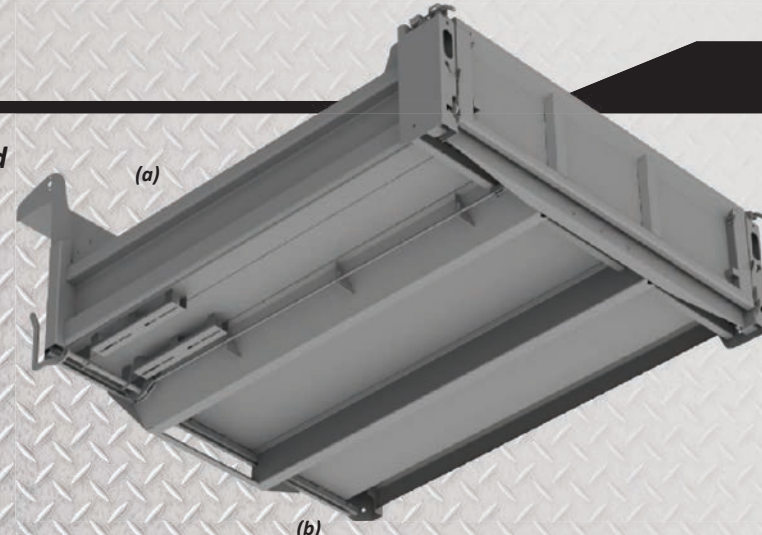

FIXED SIDE

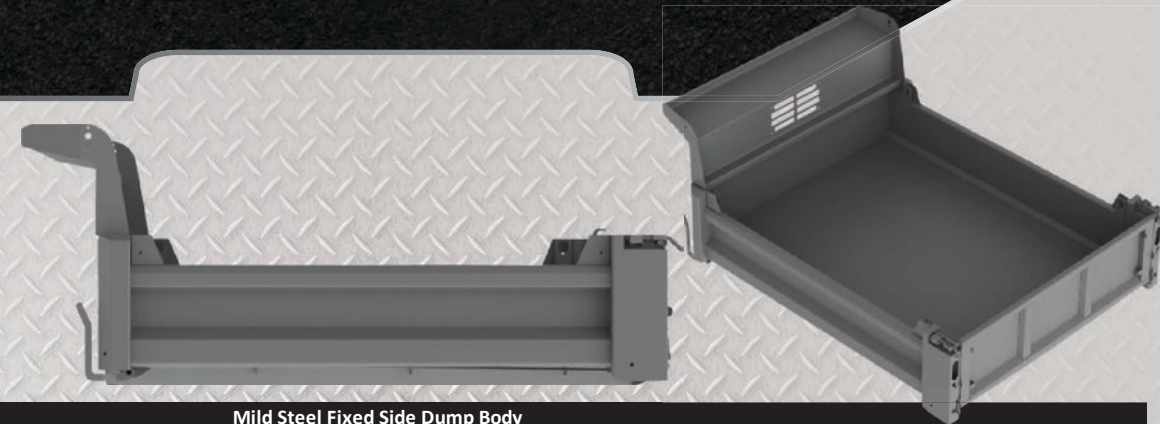

Mild Steel Fixed Side Dump Body											
Part #	Length	Side Height	Double-wall Side Walls	Floor Options	Headsheet	Double-wall Tailgate	Rear Opening Width	Max Capacity	Approx. Weight*	Std. Hoist Model	Hoist Capacity
DPD-MS-FX9	9'	12"	10-GA. Inside/ 12-GA. Outside	10- or 7-GA. GR50	12-GA. GR50	10-GA. Inside/ 14-GA. Outside	85.7"	2.0-3.0 CU. Yds.	1,488 Lbs.	SR-4016	10.6 Tons
		3.0-4.0 CU. Yds.						1,593 Lbs.	SR-4016	10.6 Tons	
		4.0-5.0 CU. Yds.						1,758 Lbs.	SR-4020	13.3 Tons	
DPD-MS-FX11	11'	12"	10-GA. Inside/ 12-GA. Outside	10- or 7-GA. GR50	12-GA. GR50	10-GA. Inside/ 14-GA. Outside	85.7"	2.0-3.0 CU. Yds.	1,698 Lbs.	SR-4016	8.5 Tons
		3.0-4.0 CU. Yds.						1,823 Lbs.	SR-4016	8.5 Tons	
		4.0-5.0 CU. Yds.						1,988 Lbs.	SR-5020	11.9 Tons	

FOLD-DOWN



Mild Steel Fold-down Side Dump Body											
Part #	Length	Side Height	Double-wall Side Walls	Floor Options	Headsheet	Double-wall Tailgate	Rear Opening Width	Max Capacity	Approx. Weight*	Std. Hoist Model	Hoist Capacity
DPD-MS-FD9	9'	12"	10-GA. Inside/ 12-GA. Outside	10- or 7-GA. GR50	12-GA. GR50	10-GA. Inside/ 14-GA. Outside	85.7"	2.0-3.0 CU. Yds.	1,513 Lbs.	SR-4016	10.6 Tons
		3.0-4.0 CU. Yds.						1,618 Lbs.	SR-4016	10.6 Tons	
		2.0-3.0 CU. Yds.						1,564 Lbs.	SR-4016	8.5 Tons	
DPD-MS-FD11	11'	12"	10-GA. Inside/ 12-GA. Outside	10- or 7-GA. GR50	12-GA. GR50	10-GA. Inside/ 14-GA. Outside	85.7"	3.0-4.0 CU. Yds.	1,848 Lbs.	SR-4016	8.5 Tons
		3.0-4.0 CU. Yds.						1,848 Lbs.	SR-4016	8.5 Tons	



DP240628.1