

KNAPHEIDE
SINCE 1848

// RAM

MECHANICS TRUCKS



KNAPHEIDE MECHANICS TRUCKS

Knapheide Mechanics Trucks come equipped with standard features to help you get the job done. With secure side compartments and an oversized cargo space, you can carry everything you need.

Choose a Knapheide Mechanics Truck for the durability and functionality that stands above the rest.

Ram chassis are compatible with KMS16, KMS30 and KMT1 models.



KMT1-11
**Body may be shown
with optional features*

// **KMT1** MECHANICS TRUCKS

The Knapheide KMT1 is purpose-built with heavy duty technicians and mechanics in mind. These bodies are built for crane load capacities of up to 7,500 lb. Knapheide KMT1 Mechanics Trucks are compatible with Class 5 trucks.

CRANE BODY UNDERSTRUCTURE

- Unique torq-isolator crane support system transfers lift forces into the full length torsion box subframe and outriggers, and not the side compartments
- Reinforced rear vertical curb side compartment is independent of all other side compartments, eliminating flexing and twisting of side packs

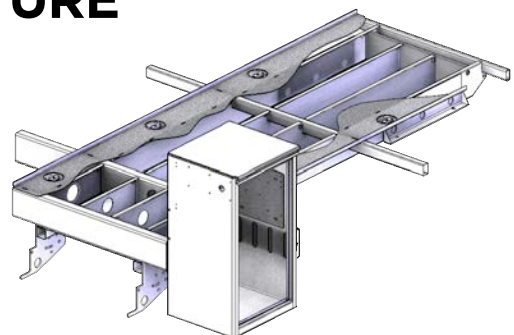

Visit knapheide.com/quote and fill out the form to receive a quote and additional product information.

STANDARD FEATURES

- A** Double paneled doors made of galvanized steel (14-gauge outer panel, 20-gauge inner panel) are reinforced with internal braces for durability
 - B** Vertical compartment doors employ double-spring over-center retainer to eliminate involuntary swing
 - C** Neoprene door seals protect compartments from the weather
 - D** Automotive quality 3-point T-handle latches
 - E** Continuous stainless steel hinges are pry-proof and corrosion-resistant
 - F** Master locking system locks down all compartments on one side with one motion
 - G** Knap-liner work surface bumper with lockable through compartment, a vise plate, and two grip strut flex steps
 - H** Two heavy duty aluminum grab handles installed on both sides at rear of the body for easy cargo access
 - I** LED S/T/T and B/U light located at the rear of the body
 - J** 16" high double panel slam tailgate with center latch and flat space for displaying company graphics
 - K** Knap-liner applied to cargo floor, sides, compartment tops, bulkhead, bumper and tailgate for durability
 - L** Includes 250-lb. capacity adjustable divider shelves
 - M** Welded-on cab protector with fully punched window for visibility
 - N** (4) LED work lights installed (2 at front, 2 at rear) for low-light working conditions
 - O** Hydraulic out-and-down curb side outrigger and hydraulic down street side outrigger for crane stability during lifting operations
 - P** 38,000 ft-lb. crane with 21' hydraulic reach, provided by a two-stage hydraulic extension
 - Q** Planetary winch provides a 60 ft. per minute single line speed
 - R** Hexagonal boom eliminates boom flex and lateral movement for ultimate stability
 - S** Up to 40 CFM reciprocating hydraulic compressor
 - T** 50'x1/2" compressor hose reel and roller fairlead through curb side vertical compartment
- Other features not shown:*
- Extreme duty aluminum mechanic 7-drawer set on street side
 - Sortimo part storage containers in horizontal compartment on street side
 - Multi-function radio remote control provides convenient complete control of the crane
 - 6 D-ring cargo tie downs installed in the cargo floor with a 6,000-lb. capacity
 - Floor is comprised of 3/16" tread plate
 - Compartment bottoms and end panels comprised of 12-gauge galvanized steel
 - Bodies are fully protected with Knapheide's water-based undercoat
 - Electrodeposition prime-paint system provides superior corrosion resistance



// **KMS16 & KMS30** **MECHANICS TRUCKS**

Knapheide KMS16 trucks are equipped with an electric crane, while KMS30 trucks have the option of either an electric or hydraulic crane for lifting applications. Both are compatible with Class 3-5 trucks.



Visit knapheide.com/quote and fill out the form to receive a quote and additional product information.

STANDARD FEATURES

- Full-length torsion box subframe
- Reinforced rear vertical curb side compartment eliminates flexing and twisting of side packs
- Double paneled doors made of 20-gauge galvanized steel are reinforced with internal braces for durability
- Vertical compartment doors employ double-spring over-center retainer to eliminate involuntary swing
- Neoprene door seals protect compartments from the weather
- Automotive-quality, rotary-style latches make opening and closing easy
- Continuous stainless steel hinges are pry-proof and corrosion-resistant
- Master locking system locks down all compartments on one side with one motion
- Knap-liner work surface bumper (KMS16)
Knap-liner work surface bumper with vise plate and two grip strut flex steps (KMS30)
- Two heavy duty aluminum grab handles installed on both sides at rear of the body for easy cargo access
- Recessed LED S/T/T and B/U lights
- Double panel slam tailgate with center latch
- Knap-liner applied to cargo floor, sides, compartment tops, bulkhead, bumper and tailgate for durability
- Includes 250-lb. capacity adjustable divider shelves
- Welded-on cab protector with fully punched window for visibility
- (2) LED work lights recessed in bulkhead for low-light working conditions
- One manual outrigger for crane stability during lifting operations
- Up to 16,000 ft-lb. crane with 20' reach
- Planetary winch provides a 15 ft. per minute single line speed
- Aluminum mechanic 7-drawer set
- Sortimo part storage containers in street side second vertical compartment
- (6) cargo tie-downs installed in the cargo area with a 2,000-lb. capacity
- Floor is comprised of 1/8" tread plate
- Compartment tops, backs, floors and end panels are comprised of 14-gauge galvanized steel
- Bodies are fully protected with Knapheide's water-based undercoat
- Electrodeposition prime-paint system provides superior corrosion resistance

POPULAR OPTIONS



**CODEABLE
PADLOCK**



**CARGO
COVER**



APU UNIT



**LED
COMPARTMENT
LIGHTS**



**STEEL
MECHANIC
DRAWERS**



**ADDITIONAL
MECHANIC
DRAWERS**



LUBE SKID



WELDER



SORTIMO

AVAILABLE MODELS

// KMT1 MODELS

MODEL	GVWR MIN./RANGE	BUMPER	BODY LENGTH	COMPARTMENT HEIGHT	COMPARTMENT DEPTH	CARGO AREA WIDTH	TOPS AND BACKS	REAR HITCH
KMT1-11	19,500	24" with step down	11'	44", 60" raised front	22"	50"	1/8" tread plate	2" receiver tube below bumper

// KMS16 & KMS30 MODELS

MODEL	GVWR MIN./RANGE	MAXIMUM CRANE	BUMPER	BODY LENGTH	COMPARTMENT HEIGHT	COMPARTMENT DEPTH	CARGO AREA WIDTH	REAR HITCH
KMS16-9	13,300-19,500	16,000 ft-lb.	18" with outrigger tube	9'	40", 60" raised front option	20"	54"	2" receiver tube below bumper
KMS16-11	13,300-19,500	16,000 ft-lb.	18" with outrigger tube	11'	40", 60" raised front option	20"	54"	2" receiver tube below bumper
KMS30-9	15,000-19,500	30,000 ft-lb.	18" with outrigger tube	9'	40", 60" raised front option	20"	54"	2" receiver tube below bumper
KMS30-11	15,000-19,500	30,000 ft-lb.	18" with outrigger tube	11'	40", 60" raised front option	20"	54"	2" receiver tube below bumper



COMMITMENT TO CORROSION RESISTANCE

Corrosion won't be a concern when you buy quality Knapheide products. To give you the best corrosion protection, we utilize a state-of-the-art, custom-designed, 12-step, SST cathodic electrodeposition finishing system, called "E-Coat."

It bonds prime paint to steel by an electroplating process to give you a superior coat of primer, resulting in better corrosion protection compared to spraying methods.

This system allows us to create products with the highest level of corrosion resistance available.

NEVER SETTLE

If you are going to be a leader, it takes more than building a high-quality product. It means never being totally satisfied with that product, no matter how high quality it may be. It requires constant vigilance and a willingness to take a chance on something new. And it means exceeding expectations every time. As the industry changes, one thing never will—our commitment to making customers like you as productive and efficient as possible. We know you don't settle, and we don't either. That's why we want you never to settle for anything less than Knapheide on the back of your truck.

Knapheide. Never settle.

SIX-YEAR, LIMITED WARRANTY



NO RUST
THROUGH



DOOR HINGES WILL
NOT FAIL OR COME
OFF BODY



LATCHES AND LOCK
CYLINDERS WILL NOT
FAIL TO OPERATE



SHELVES WILL NOT
BEND UNDER MAX.
LOAD OF 250 LBS.

Visit www.knapheide.com/warranty for more information.



The Knapheide Manufacturing Company
1848 Westphalia Strasse | Quincy, IL 62305

217-222-7131
www.knapheide.com
knapheide@knapheide.com

KNAPHEIDE
SINCE 1848